

# 1. CRANKCASE

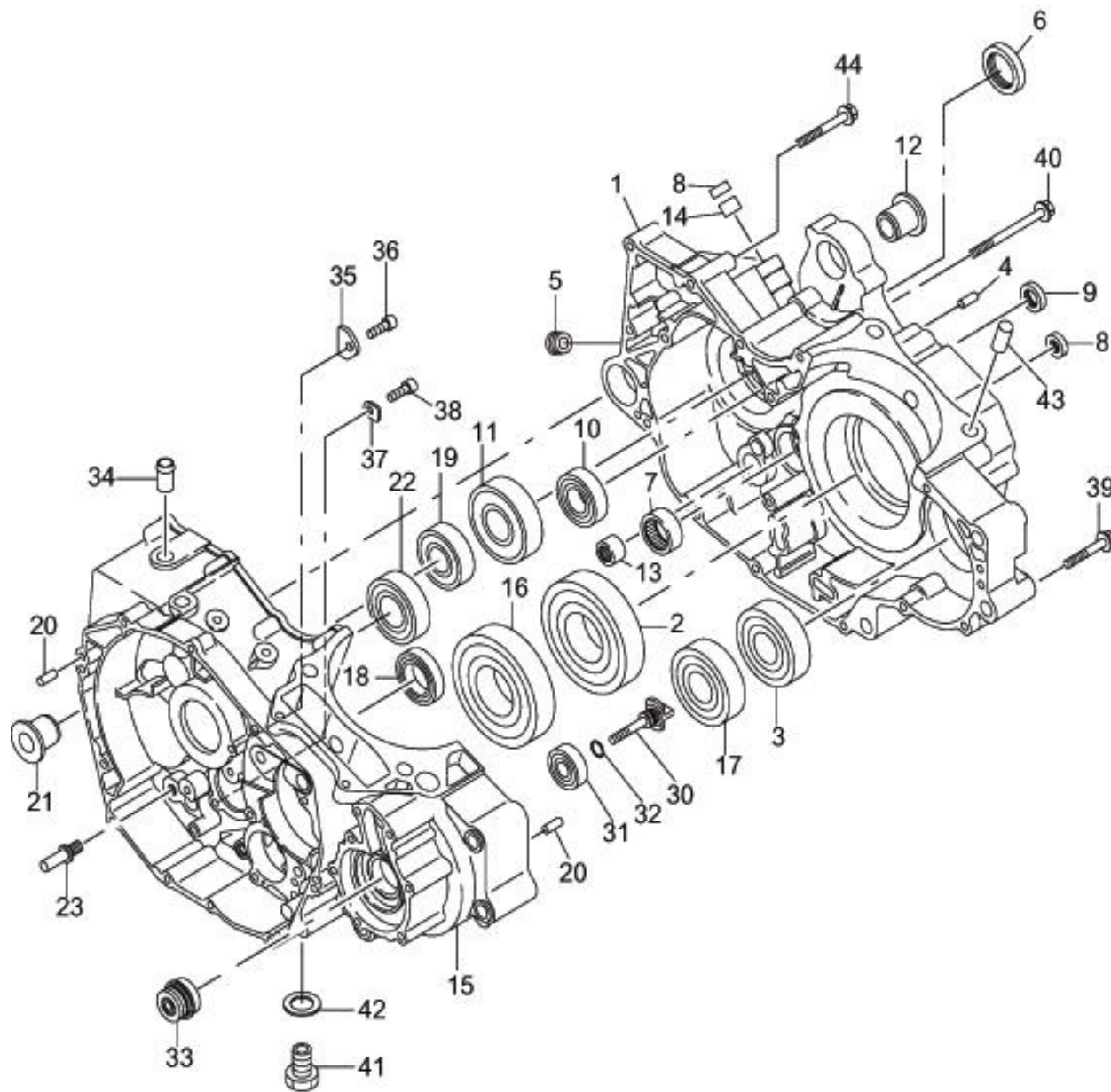

# 1. CRANKCASE

Item	Part-No.	DL-Part No.	Part Name	Specification	Q'ty of Usage	Note
*1	290-10301-00		CRANKCASE ASSY.	Incl. 2~23,30~40	1	
2	060-03502-21	A010056-00	BALL BEARING	3TMB-6308	1	
3	060-02501-70	A010063-00	BALL BEARING	TMB305X77 C3	1	
4	031-00600-10		DOWEL PIN		2	
5	235-15421-03		BLIND PLUG	PT1/8	1	
6	044-02500-70	A030036-00	OIL SEAL	TB25X38X7	1	
7	061-01300-00	A010061-00	NEEDLE BEARING	HK2512	1	
8	044-01200-30	A030037-00	OIL SEAL	KC12X18X5	2	
9	044-01300-20	A030038-00	OIL SEAL	TC13X22X5	1	
10	060-02001-50	A010026-00	BALL BEARING	6004LU	1	
11	060-02501-10	A040065-03	BALL BEARING	6305LU	1	
12	283-16401-03		COLLAR		1	
13	061-02500-10	A010060-00	NEEDLE BEARING	HK1312	1	
14	060-21200-10		BEARING (RELEASE)		1	
16	060-03502-21	A010056-00	BALL BEARING	3TM-6308	1	
17	060-02501-70	A010063-00	BALL BEARING	TMB305X77 C3	1	
18	060-02501-20	A010062-00	BALL BEARING	6905	1	
19	060-02000-20	A010064-00	BALL BEARING	6204	1	
20	031-00600-10		DOWEL PIN		4	
21	283-16401-03		COLLAR		1	
22	060-02501-30	A010059-00	BALL BEARING	TMB205	1	
23	257-88901-03		STOPPER PIN		1	
*30	283-55002-01		WATER PUMP SHAFT COMPL.	Incl. 31,32	1	

# 1. CRANKCASE

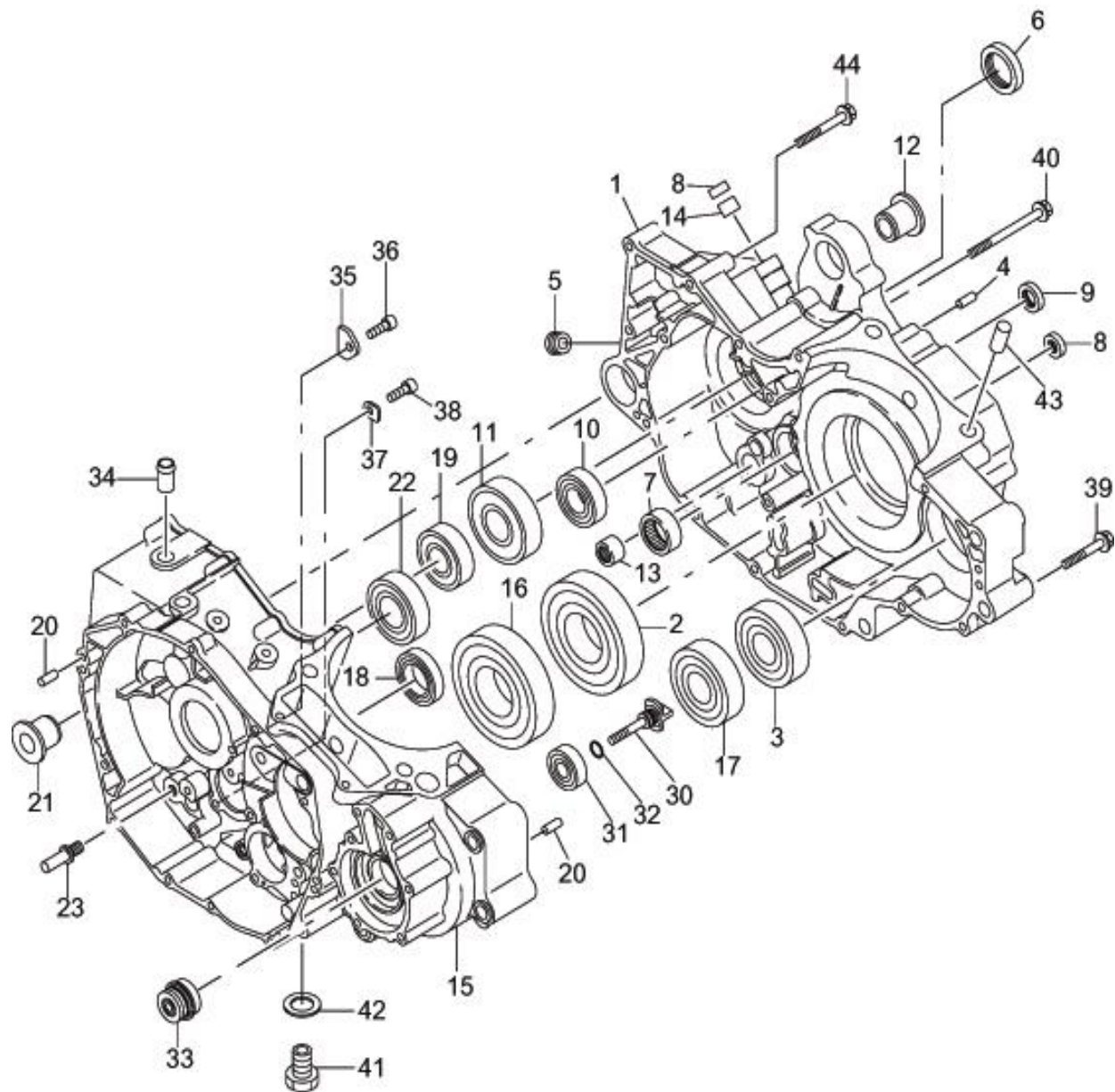

# 1. CRANKCASE

Item	Part-No.	DL-Part No.	Part Name	Specification	Q'ty of Usage	Note
31	060-01200-60	A010058-00	BALL BEARING	6201DU2	1	
32	006-26100-90	A040036-00	"O" RING	O-R8.8X1.9	1	
33	257-56201-01	A030039-00	MECHANICAL SEAL COMPL.	WF58X13X1.8	1	
34	132-97KA0-60		PIPE-AIR BREATHER		1	
35	283-15503-03		STOPPER PLATE		1	
36	011-90600-90		BOLT (SOCKET HEAD)	M6×16mm	1	
37	283-15504-03		STOPPER PLATE B		2	
38	011-90600-50		BOLT (SOCKET HEAD)	M6×12mm	2	
39	011-00605-20		FLANGE BOLT	M6×40mm	7	
40	011-00605-30		FLANGE BOLT	M6×75mm	8	
41	283-69301-13		PLUG (MAGNETO)		1	
42	021-11400-20		GASKET		1	
43	031-51500-10		PIPE KNOCK	For M11	2	
44	011-00605-40		FLANGE BOLT	M6×50mm	1	

## 2. CYLINDER

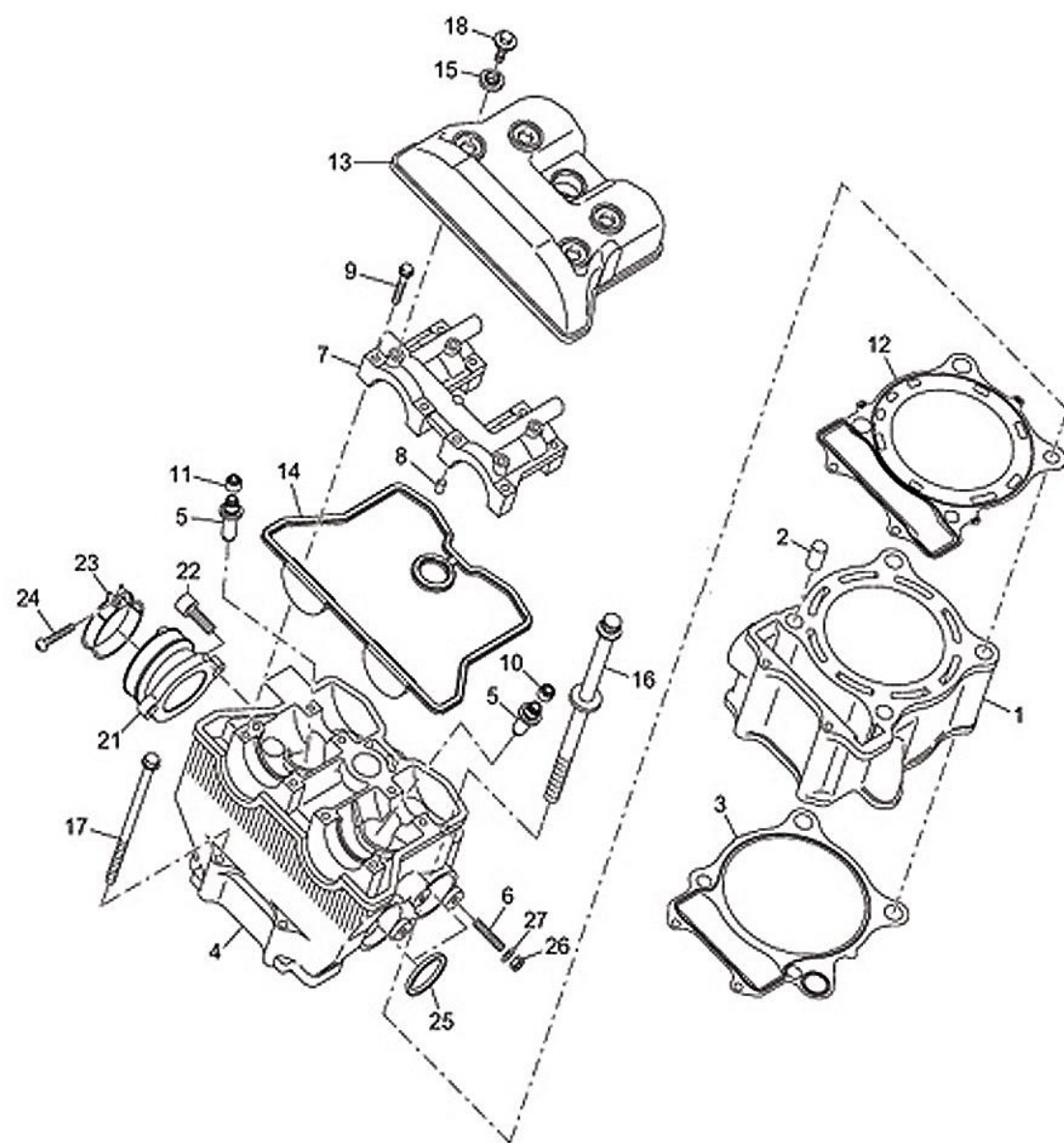

## 2. CYLINDER

Item	Part-No.	DL-Part No.	Part Name	Specification	Q'ty of Usage	Note
1	290-12401-01		CYLINDER COMPL.		1	
2	031-51500-10		PIPE KNOCK	For M11	2	
3	283-15201-13	E140014-00	GASKET (CYLINDER)		1	
*4	290-13002-00		CYLINDER HEAD ASSY.	Incl. 5~11	1	
5	283-14202-03		GUIDE VALVE		4	
6	010-50804-01		STUD		4	
8	980-40081-10		STRAIGHT PIN	For M6	2	
9	011-00605-20		FLAGNE BOLT	M6×40mm	8	
10	283-16001-03		SEAL-VALVE		2	
11	283-15901-03		SEAL-INTAKE VALVE		2	
12	290-15102-01	E140006-00	GASKET COMPL. ( HEAD )		1	
13	290-36301-03		HEAD COVER		1	
14	283-36101-13		"O" RING (HEAD COVER)		1	
15	283-36001-03		RUBBER MOUNT		4	
16	283-16201-03		BOLT AND WASHER ASSY.	M11×198mm	4	
17	011-00604-10		FLANGE BOLT	M6×140mm	2	
18	283-36201-03		BOLT	M6×14mm	4	
21	283-65001-01		ADAPTER COMPL.		1	
22	011-90800-20		BOLT(SOCKET HEAD)	M8×20mm	2	
*23	283-65901-00		BAND ASSY. (ADAPTER)	Incl. 24	1	
24	004-31043-00		SCREW, PANHEAD	M4×30mm	1	
25	283-36901-01		GASKET COMPL. (EXHAUST)		2	
26	017-20800-20		NUT		4	
27	003-20080-00		SPRING WASHER		4	

### 3. CRANKSHAFT & PISTON

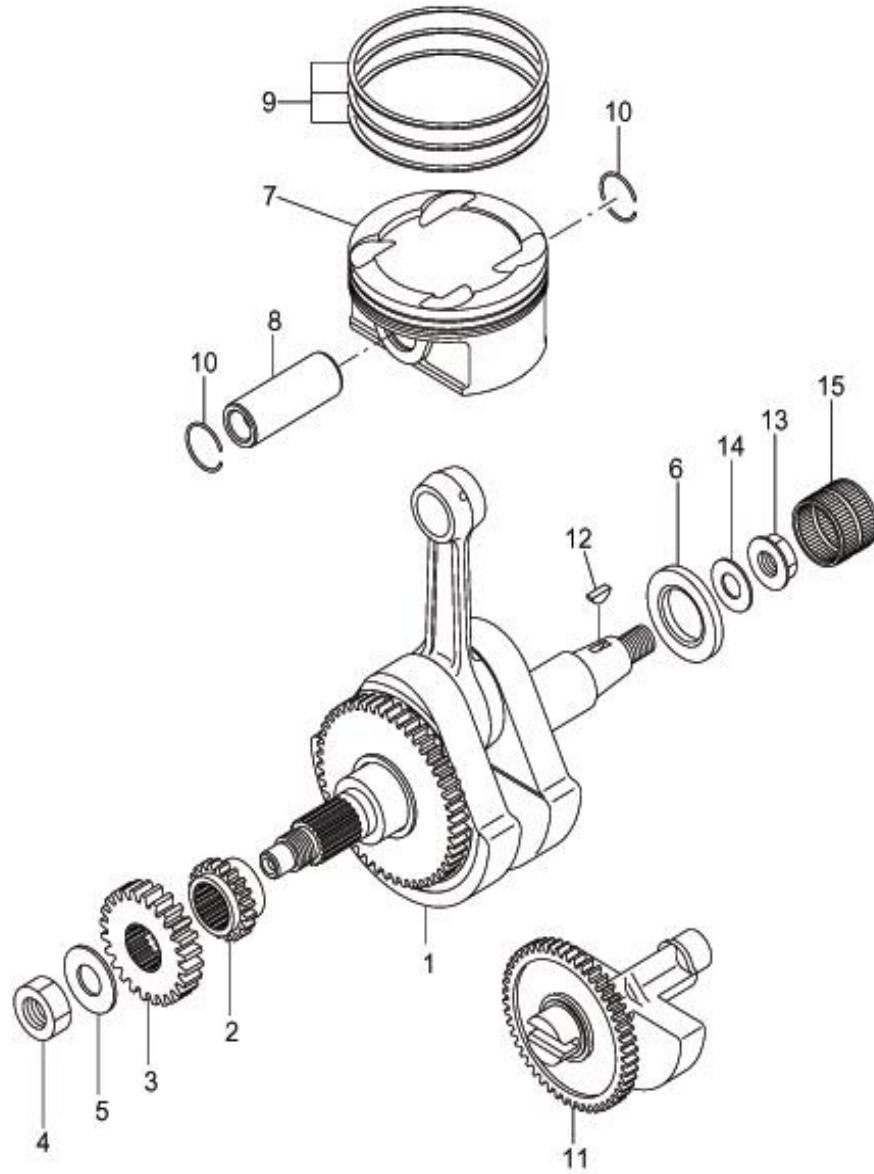

### 3. CRANKSHAFT & PISTON

Item	Part-No.	DL-Part No.	Part Name	Specification	Q'ty of Usage	Note
1	283-20301-00		CRANKSHAFT ASSY.		1	
2	283-35202-03		CRANK SPROCKET		1	
3	283-25003-03		PRIMARY GEAR (DRIVE)		1	
4	017-01800-50		NUT		1	
5	020-01800-40		WASHER		1	
6	283-26001-03		SPACER		1	
*7	290-23401-07		PISTON SET (STD)	Incl. 7,10	1	
8	283-23301-03	E140021-00	PISTON PIN		1	
9	290-23501-07	E140007-00	PISTON RING SET (STD)		1	
10	056-52300-20	A100047-00	CLIP		2	
11	283-24105-01		BALANCER SHAFT COMPL.		1	
12	032-30400-70		WOODRUFF KEY		1	
13	018-01400-20		FLANGE NUT		1	
14	020-01400-30		WASHER		1	
15	283-76201-03	A010057-00	NEEDLE BEARING	K30X35X26ZW	1	

## 4. INTAKE & EXHAUST

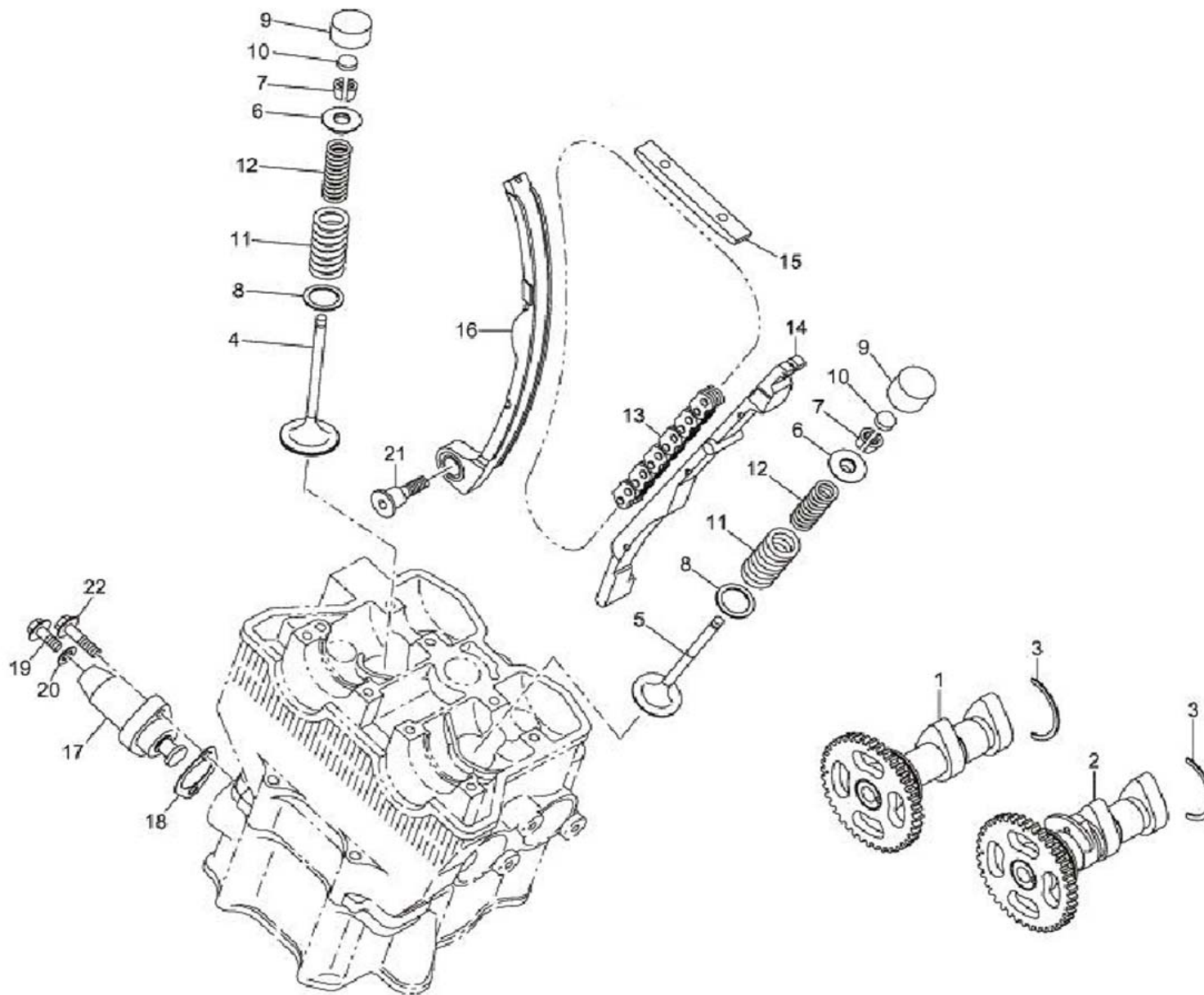

#### 4. INTAKE & EXHAUST

Item	Part-No.	DL-Part No.	Part Name	Specification	Q'ty of Usage	Note
1	283-31601-01		CAMSHAFT (IN) COMPL.		1	
2	283-31602-11		CAMSHAFT (EX) COMPL.		1	
3	283-35601-03		BEARING STOPPER		2	
4	287-33401-03	E140019-00	INTAKE VALVE		2	
5	287-33501-03	E140020-00	EXHAUST VALVE		2	
6	283-33701-03		SPRING RETAINER		4	
7	132-10AA0-20		COLLET-VALVE		8	
8	283-35701-03		SEAT (VALVE SPRING)		4	
9	283-35801-03		VALVE LIFTER		4	
10	283-35901-03		ADJUSTING PAD	T=1.450	4	
10	283-35902-03		ADJUSTING PAD	T=1.500	4	
10	283-35903-03		ADJUSTING PAD	T=1.550	4	
10	283-35904-03		ADJUSTING PAD	T=1.600	4	
10	283-35905-03		ADJUSTING PAD	T=1.625	4	
10	283-35906-03		ADJUSTING PAD	T=1.650	4	
10	283-35907-03		ADJUSTING PAD	T=1.675	4	
10	283-35908-03		ADJUSTING PAD	T=1.700	4	
10	283-35909-03		ADJUSTING PAD	T=1.725	4	
10	283-35910-03		ADJUSTING PAD	T=1.750	4	
10	283-35911-03		ADJUSTING PAD	T=1.775	4	
10	283-35912-03		ADJUSTING PAD	T=1.800	4	
10	283-35913-03		ADJUSTING PAD	T=1.825	4	
10	283-35914-03		ADJUSTING PAD	T=1.850	4	
10	283-35915-03		ADJUSTING PAD	T=1.875	4	
10	283-35916-03		ADJUSTING PAD	T=1.900	4	

## 4. INTAKE & EXHAUST

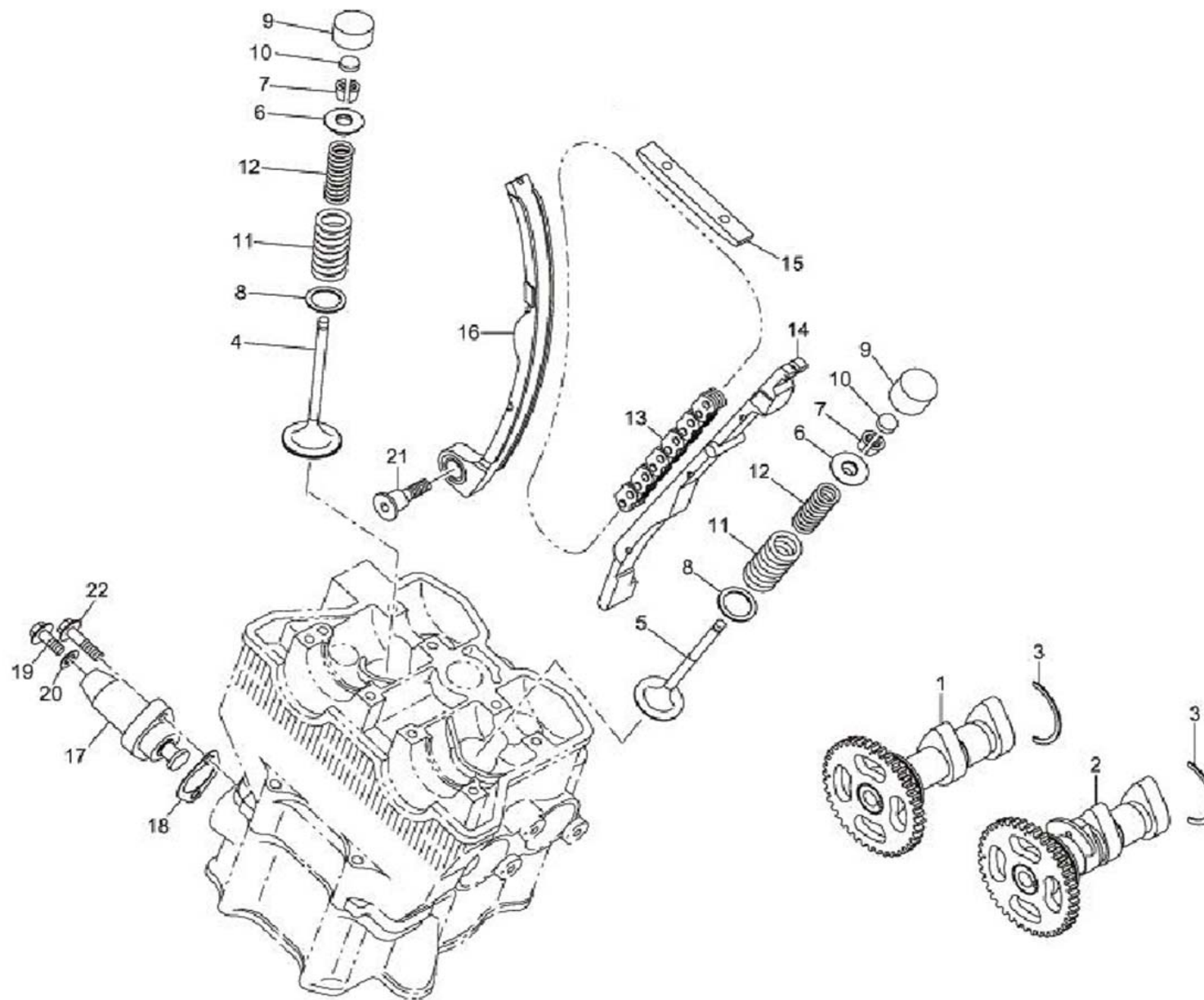

#### 4. INTAKE & EXHAUST

Item	Part-No.	DL-Part No.	Part Name	Specification	Q'ty of Usage	Note
10	283-35917-03		ADJUSTING PAD	T=1.925	4	
10	283-35918-03		ADJUSTING PAD	T=1.950	4	
10	283-35919-03		ADJUSTING PAD	T=1.975	4	
10	283-35920-03		ADJUSTING PAD	T=2.000	4	
10	283-35921-03		ADJUSTING PAD	T=2.025	4	
10	283-35922-03		ADJUSTING PAD	T=2.050	4	
10	283-35923-03		ADJUSTING PAD	T=2.075	4	
10	283-35924-03		ADJUSTING PAD	T=2.100	4	
10	283-35925-03		ADJUSTING PAD	T=2.125	4	
10	283-35926-03		ADJUSTING PAD	T=2.150	4	
10	283-35927-03		ADJUSTING PAD	T=2.200	4	
10	283-35928-03		ADJUSTING PAD	T=2.250	4	
10	283-35929-03		ADJUSTING PAD	T=2.300	4	
11	283-33601-03	A110051-00	VALVE SPRING (OUTER)		4	
12	283-33602-03	A110047-00	VALVE SPRING (INNER)		4	
13	283-37001-03	E140015-00	TIMING CHAIN		1	
14	283-37102-03		CHAIN GUIDE 1		1	
15	283-37201-03		CHAIN GUIDE 2		1	
16	283-37303-01		LEVER COMPL.		1	
17	283-36401-00		TENSIONER ASSY.		1	
18	283-36801-03	E140008-00	GASKET (TENSIONER)		1	
19	011-00600-10		FLANGE BOLT	M6×8mm	1	
20	021-10600-20		GASKET, ALUMINIUM		1	
21	283-37401-03		PIVOT BOLT	M8×22.5mm	1	
22	011-00602-40		FLANGE BOLT	M6×25mm	2	

## 5. WATER PUMP

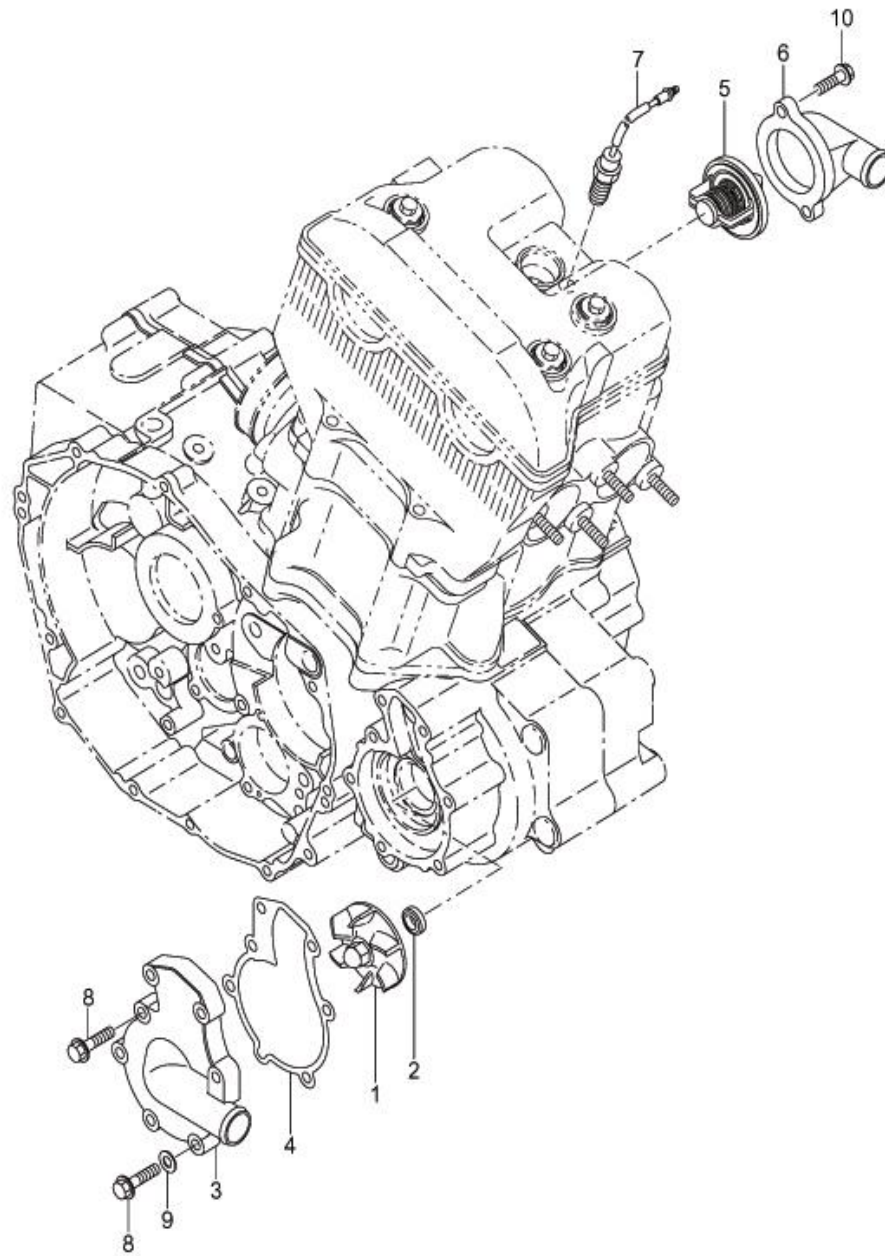

## 5. WATER PUMP

Item	Part-No.	DL-Part No.	Part Name	Specification	Q'ty of Usage	Note
1	283-55102-13		IMPELLER		1	
2	021-80600-10		SEAL WASHER		1	
3	290-55202-03		WATER PUMP CASE		1	
4	283-55602-13	E140009-00	GASKET (WATER PUMP)		1	
5	283-56101-01		THERMO STAT COMPL.		1	
6	290-55301-03		THERMO COVER		1	
7	257-56002-01		THERMO SWITCH COMPL.	110 DEG.	1	
8	011-00602-40		FLANGE BOLT	M6×25mm	7	
9	021-10600-30		GASKET, COPPER		1	
10	011-00602-30		FLANGE BOLT	M6×20mm	2	

## 6. CARBURETOR

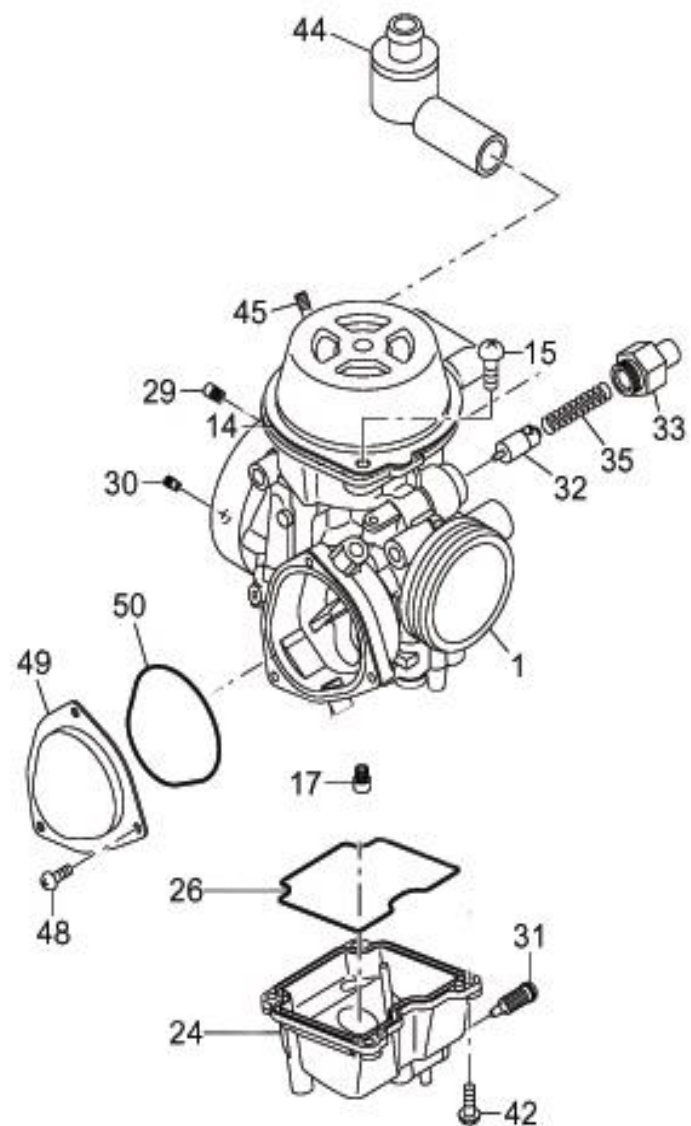

## 6. CARBURETOR

Item	Part-No.	DL-Part No.	Part Name	Specification	Q'ty of Usage	Note
*1	283-62301-20		CARBURETOR ASSY.	Incl. 2~50,Mark "83L01B	1	
14	283-62355-08		DIAPHRAGM COVER		1	
15	212-62361-08		SCREW		2	
16	230-62402-08		JET(#42.5)		1	
17	113-62303-08		MAIN JET(#150)		1	
24	283-62360-08		FLOAT BODY		1	
26	283-62362-08		"O"RING		1	
27	283-62500-08		NEEDLE VALVE		1	
28	283-62300-08		NEEDLE JET		1	
29	266-62409-08		JET(#110)		1	
30	283-62363-08		JET(#120)		1	
31	257-62364-08		SCREW		1	
32	257-82373-08		PLUNGER ASSY.		1	
33	283-62364-08		GUIDE HOLDER		1	
35	106-62460-08		SPRING		1	
42	283-62367-08		SCREW		4	
44	283-62368-08		FILTER		1	
45	248-62410-08		AIR JET		1	
48	226-62354-08		SCREW		3	
49	260-62365-08		COVER		1	
50	260-62364-08		"O"RING		1	

## 7. OIL PUMP

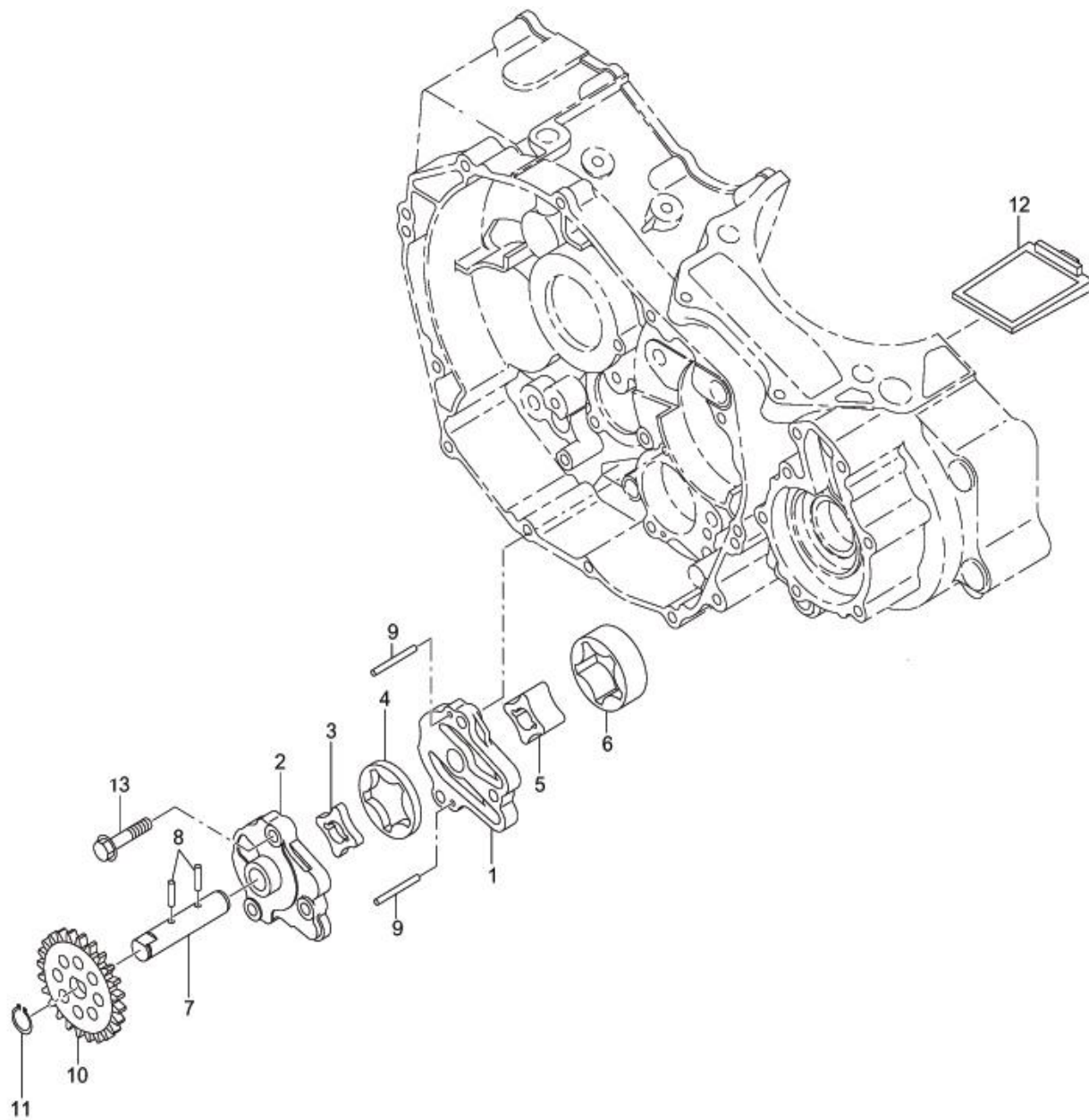

## 7. OIL PUMP

Item	Part-No.	DL-Part No.	Part Name	Specification	Q'ty of Usage	Note
*1	283-65102-00		OIL PUMP ASSY.	Incl. 1~9	1	
1	283-65101-03		OIL PUMP CASE 1		1	
2	283-65202-03		OIL PUMP CASE 2		1	
3	283-66102-03		INNER ROTOR (FEED)		1	
4	283-66202-03		OUTER ROTOR (FEED)		1	
5	283-66301-03		INNER ROTOR (SCAV)		1	
6	283-66401-03		OUTER ROTOR (SCAV)		1	
7	283-65302-03		OIL PUMP SHAFT		1	
8	031-00300-30		DOWEL PIN		2	
9	031-00300-40		DOWEL PIN		2	
10	283-64104-03		OIL PUMP GEAR		1	
11	003-15120-00		SNAP RING		1	
12	283-65801-02		OIL STRAINER UNIT		1	
13	011-00604-20		FLANGE BOLT	M6×30mm	3	

## 8. OIL FILTER

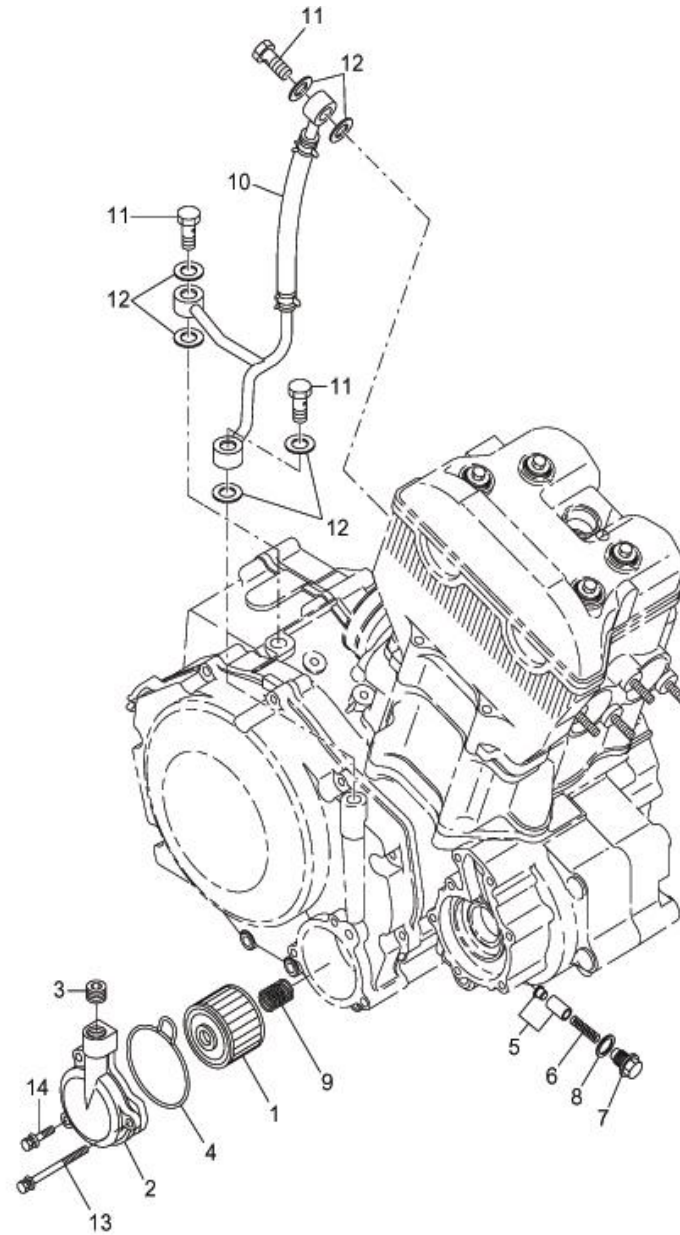

## 8. OIL FILTER

Item	Part-No.	DL-Part No.	Part Name	Specification	Q'ty of Usage	Note
1	283-65401-01		OIL FILTER COMPL.		1	
*2	290-65501-00		FILTER COVER ASSY.	Incl. 2,3	1	
2	290-65502-01		FILTER COVER COMPL.		1	
3	040-31400-10		PLUG	PT1/4	1	
4	283-67501-03	E140016-00	"O" RING (FILTER COVER)		1	
5	283-66501-00		VALVE (ONE WAY) ASSY.		1	
6	283-66601-03		SPRING (ONE WAY VALVE)		1	
7	283-66701-03		PLUG (ONE WAY)		1	
8	021-11100-10		GASKET, ALUMINUM		1	
9	283-65401-03	A110048-00	SPRING (FILTER)		1	
10	283-68002-00		OIL DELIVERY PIPE ASSY.		1	
11	053-01200-41		BANJO BOLT		3	
12	021-11200-50		GASKET		6	
13	011-00604-50		FLANGE BOLT	M6×65mm	1	
14	011-00602-40		FLANGE BOLT	M6×25mm	2	

# 9. MAGNETO

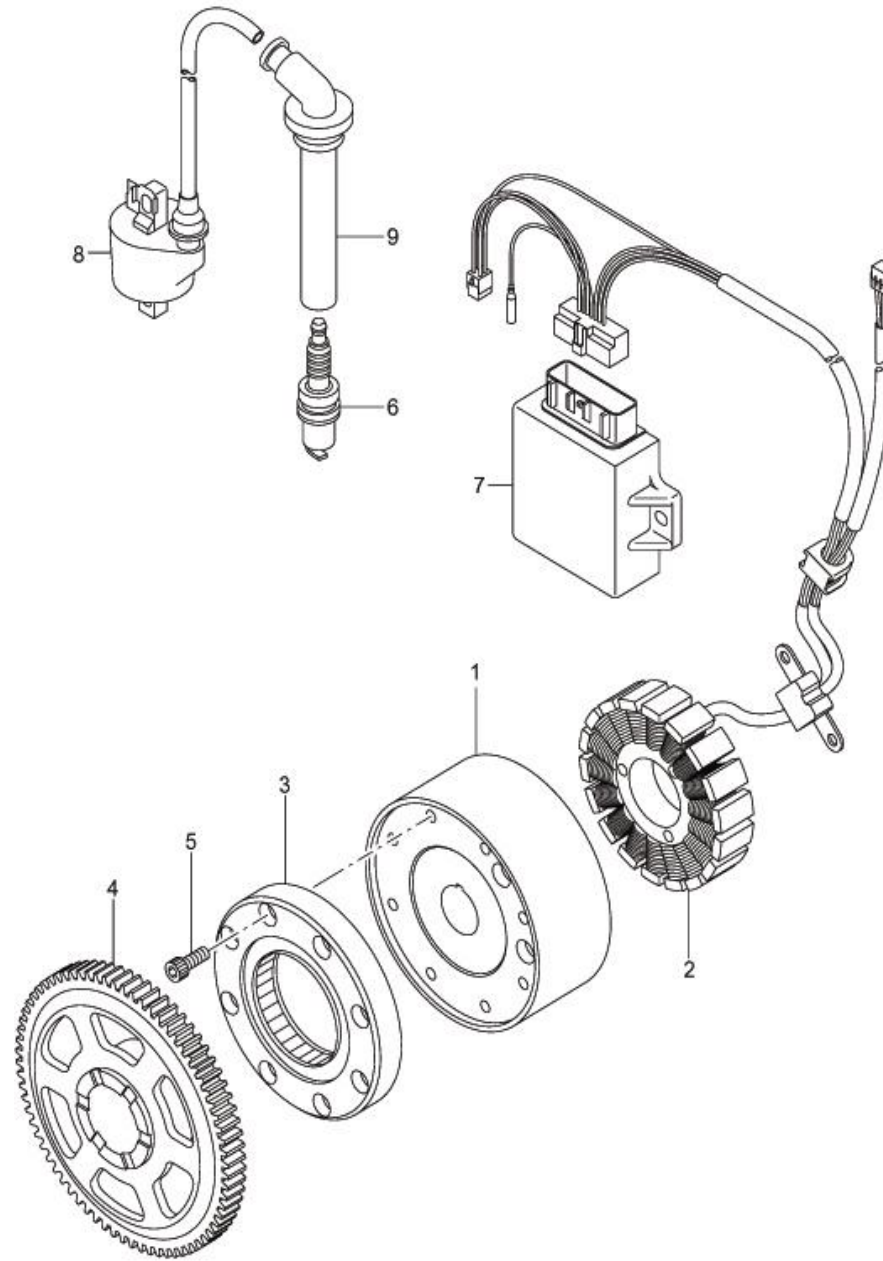

## 9. MAGNETO

Item	Part-No.	DL-Part No.	Part Name	Specification	Q'ty of Usage	Note
*1	283-70102-10		MAGNETO ASSY.	Incl. 1,2	1	
1	283-70110-08		FLYWHEEL ASSY		1	
2	283-70210-08		STATOR ASSY.		1	
3	283-75602-00		ONE WAY CLUTCH ASSY.		1	
4	283-75501-03		STARTER GEAR		1	
5	011-90600-80		BOLT (SOCKET HEAD)	M6×16mm	8	
6	065-01407-60		SPARK PLUG	DCPR8E	1	
7	283-72202-01		CDI SYSTEM COMPL.		1	
8	283-71201-01		IGNITION COIL COMPL.		1	
9	283-76301-03		SPARK PLUG CAP		1	

## 10. MAG COVER

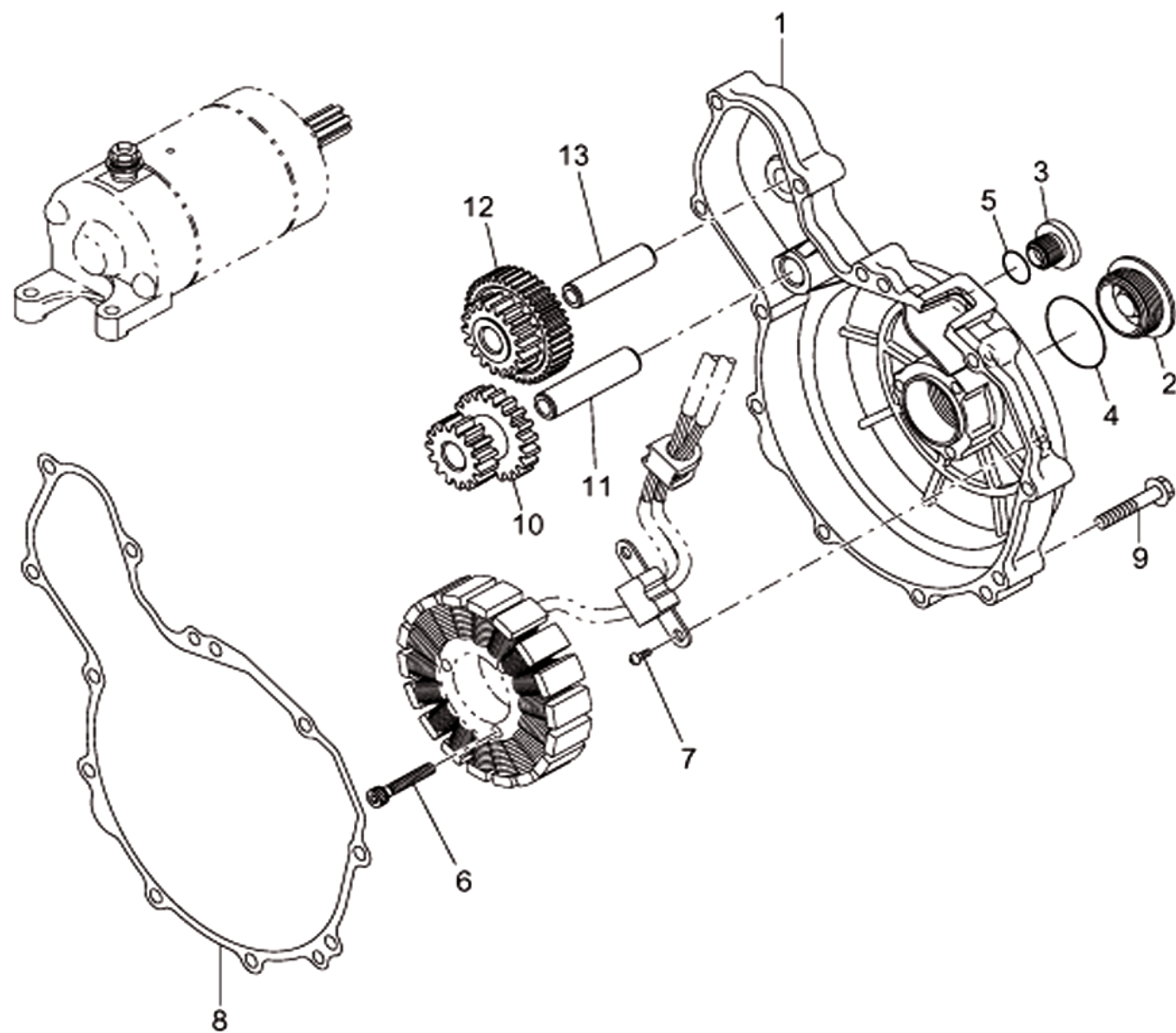

## 10. MAG COVER

Item	Part-No.	DL-Part No.	Part Name	Specification	Q'ty of Usage	Note
1	290-71701-01		MAG COVER COMPL.		1	
2	283-77101-03	E140010-00	PLUG 1 (MAG COVER)		1	
3	283-77201-03	E140011-00	PLUG 2 (MAG COVER)		1	
4	024-02700-40	A040038-00	"O" RING	P29-28.7x2.4	1	
5	024-01200-10	A040037-00	"O" RING	12.3X2.4	1	
6	011-90500-40		BOLT (SOCKET HEAD)	M5x30mm	3	
7	004-35051-20		SCREW AND WASHER ASSY.	M5x12mm	2	
8	283-75001-13	E140012-00	GASKET (MAG COVER)		1	
9	011-00604-30		FLANGE BOLT	M6x35mm	11	
10	283-75101-03		REDUCTION GEAR 1		1	
11	283-75201-03		SHAFT 1		1	
12	283-75301-03		REDUCTION GEAR 2		1	
13	283-75401-03		SHAFT 2		1	

# 11. STARTING MOTOR

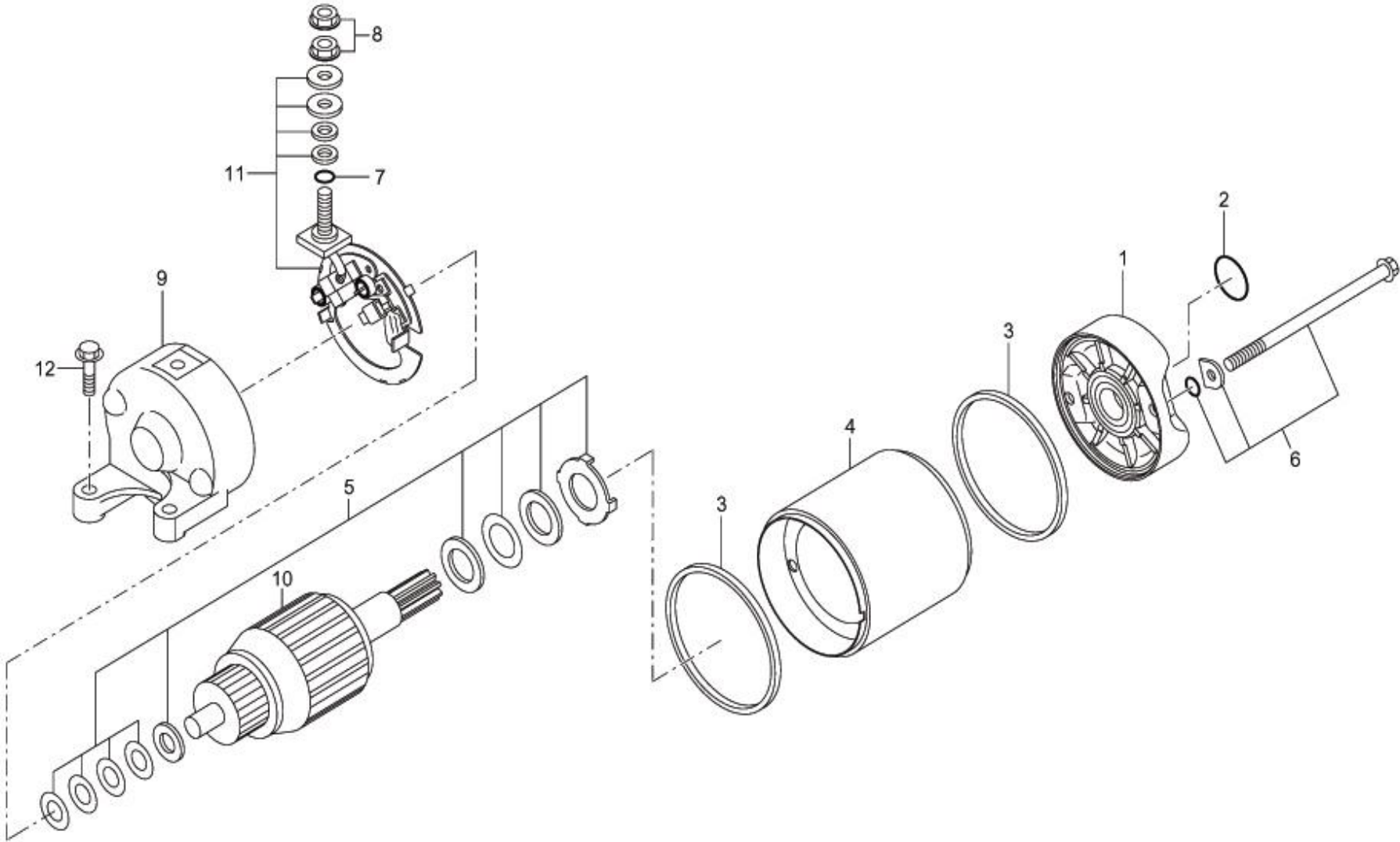

## 11. STARTING MOTOR

Item	Part-No.	DL-Part No.	Part Name	Specification	Q'ty of Usage	Note
*1	283-70501-00		STARTING MOTOR ASSY.	Incl. 1~11	1	
*1	257-70501-08		FRONT BRACKET ASSY.	Incl. 2	1	
2	164-70553-08		"O"RING		1	
3	155-70572-08		RUBBER RING		2	
5	257-70550-08		WASHER SET		1	
6	257-70551-08		SET BOLT ASSY.		2	
7	155-70575-08		"O"RING		3	
8	155-70554-08		FLANGE NUT		1	
9	283-70505-08		REAR BRACKET ASSY.		1	
10	257-70552-08		ARMATURE ASSY.		1	
11	155-70573-08		CARBON BRUSH SET		1	
12	011-00602-40		FLANGE BOLT	M6×25mm	2	

## 12. CLUTCH (No.1)

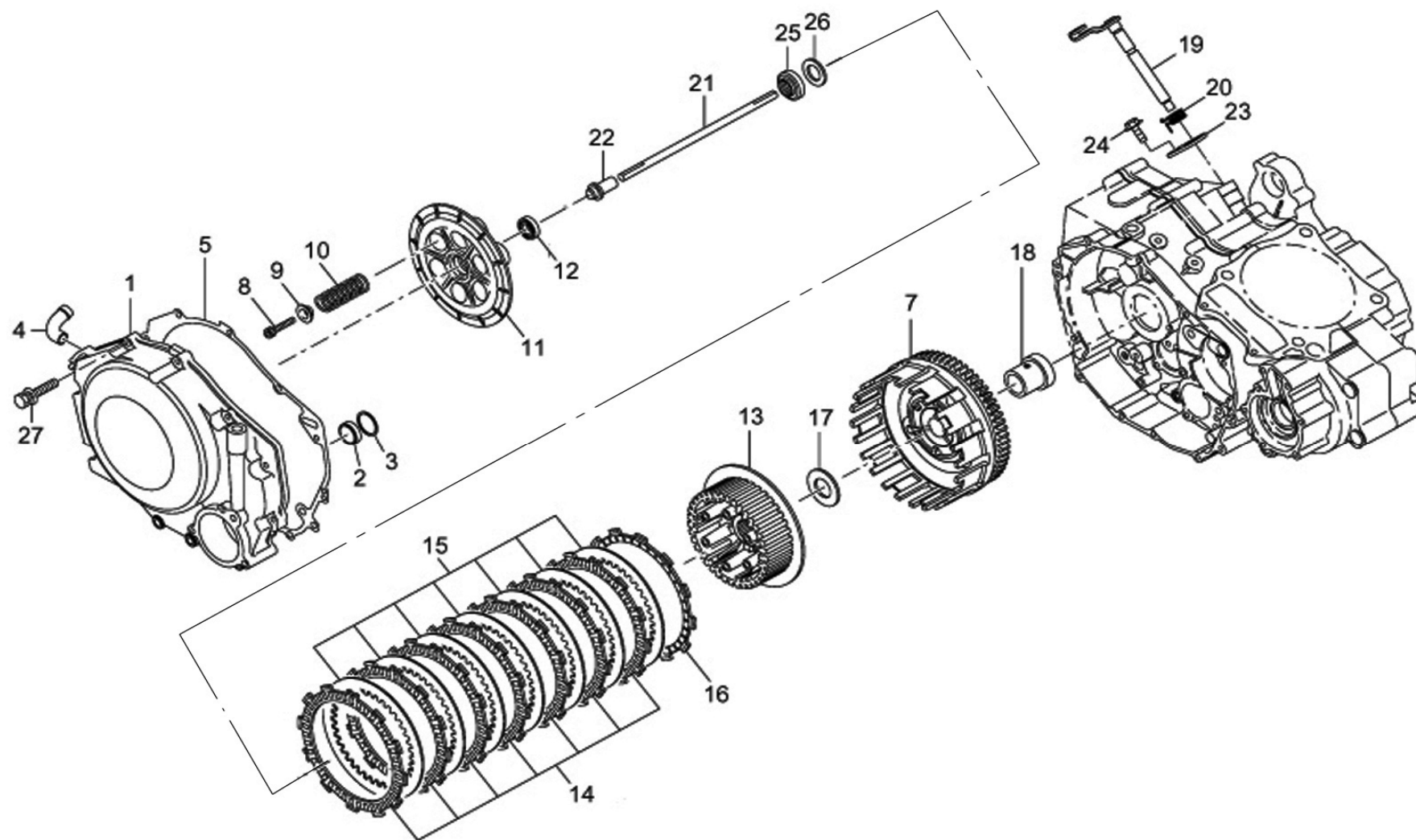

## 12. CLUTCH (No.1)

Item	Part-No.	DL-Part No.	Part Name	Specification	Q'ty of Usage	Note
*1	290-85002-11		CLUTCH COVER COMPL.	Incl. 2~4	1	
2	283-85101-03	E140017-00	OIL SEAL (CRANK)		1	
3	003-14260-00		SNAP RING, INNER		1	
4	271-38201-01		PIPE COMPL.		1	
5	283-85302-03	E140013-00	GASKET (CLUTCH COVER)		1	
*6	283-83903-00		CLUTCH ASSY. (MULTI)	Incl. 7~17	1	
7	283-83914-08		OUTER COMPL.,CLUTCH		1	
8	283-83903-08		BOLT	M6×35mm	6	
9	283-83905-08		WASHER, CLUTCH SPRING		6	
10	283-83904-08		SPRING (CLUTCH)		6	
11	283-83909-08		DISK, CLUTCH PRESSURE		1	
12	283-83910-08		BALL BEARING		1	
13	283-83902-08		CENTER COMPL.,CLUTCH		1	
14	283-83915-08		DISK A, CLUTCH FRICTION		7	
15	283-83908-08		PLATE, CLUTCH		7	
16	283-83907-08		DISK B, CLUTCH FRICTION		1	
17	283-83913-08		WASHER,THRUST		1	
18	283-85502-03		DISTANCE COLLAR		1	
19	283-85601-01		RELEASE SHAFT COMPL.		1	
20	283-85701-03	A110049-00	SPRING (RELEASE)		1	
21	283-85802-03		PUSH ROD		1	
22	283-85901-03		PUSHER		1	
23	283-86102-03		PLATE (RELEASE SHAFT)		1	
26	980-35180-20		LOCK WASHER		1	
27	011-00602-40		FLANGE BOLT	M6×25mm	11	

# 13. CLUTCH (No.2)

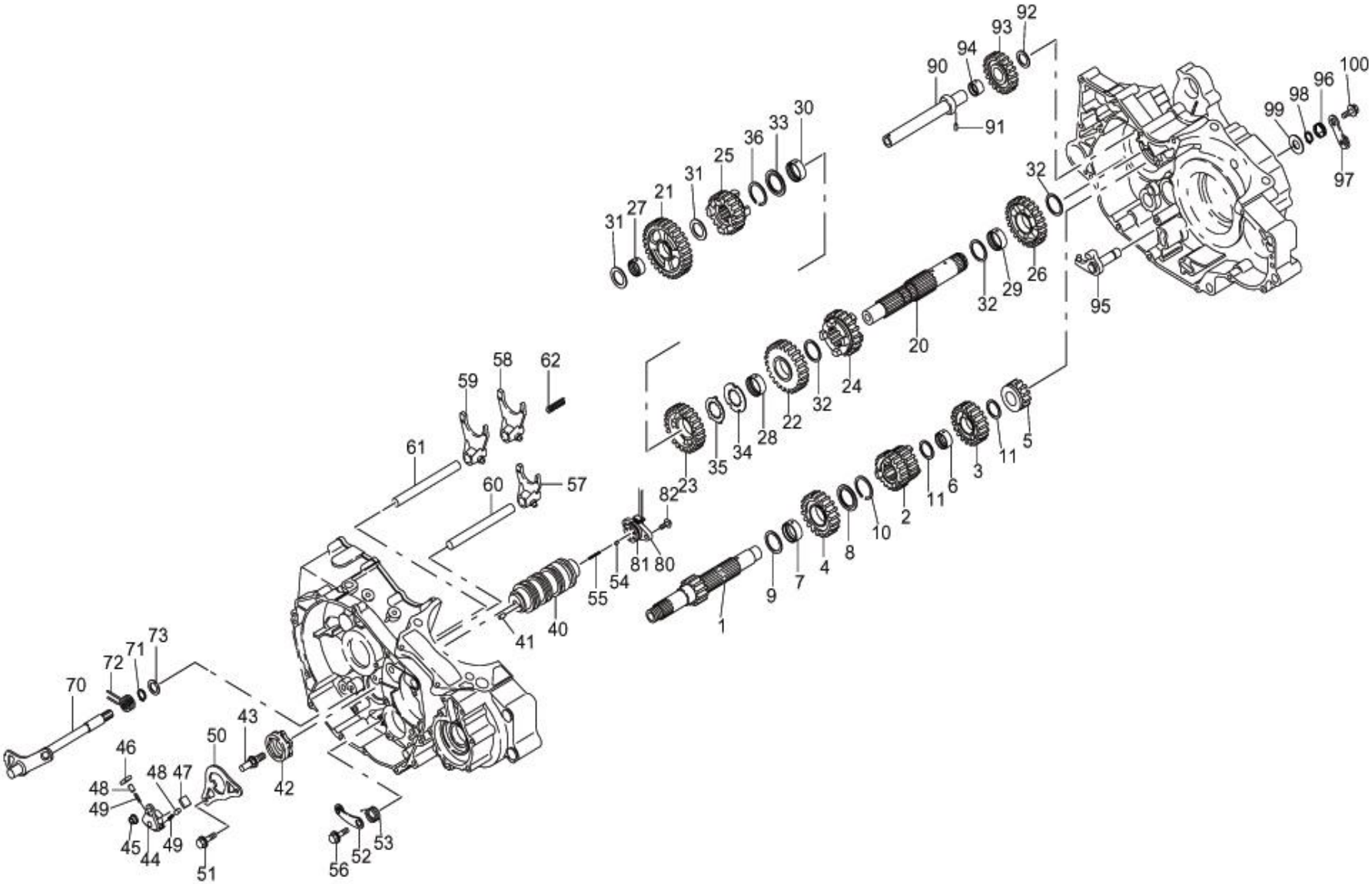

### 13. CLUTCH (No.2)

Item	Part-No.	DL-Part No.	Part Name	Specification	Q'ty of Usage	Note
*1	283-86202-00		MAIN SHAFT ASSY.	Incl. 1~11	1	
1	283-86202-01		MAIN SHAFT COMPL.		1	
2	283-82208-03		GEAR (2ND,3RD DRIVE)		1	
3	283-82212-03		GEAR (4TH DRIVE)		1	
4	283-82213-03		GEAR (5TH DRIVE)		1	
5	283-82211-03		REVERSE GEAR (DRIVE)		1	
6	283-86406-03		COLLAR		1	
7	283-86405-03		COLLAR		1	
8	283-86701-03		SPLINE WASHER		1	
9	283-86802-03		WASHER		1	
10	283-86901-03		CLIP		1	
11	283-86804-03		WASHER		2	
*20	283-87002-00		COUNTER SHAFT ASSY.	Incl. 20~36	1	
20	283-87002-01		COUNTER SHAFT COMPL.		1	
21	283-82106-03		GEAR (1ST DRIVEN)		1	
22	283-82107-03		GEAR (2ND DRIVEN)		1	
23	283-82108-03		GEAR (3RD DRIVEN)		1	
24	283-82109-03		GEAR (4TH DRIVEN)		1	
25	283-82110-03		GEAR (5TH DRIVEN)		1	
26	283-82111-03		REVERSE GEAR (DRIVEN)		1	
27	283-86403-03		COLLAR		1	
28	283-86409-03		COLLAR		1	
29	283-86405-03		COLLAR		1	

# 13. CLUTCH (No.2)

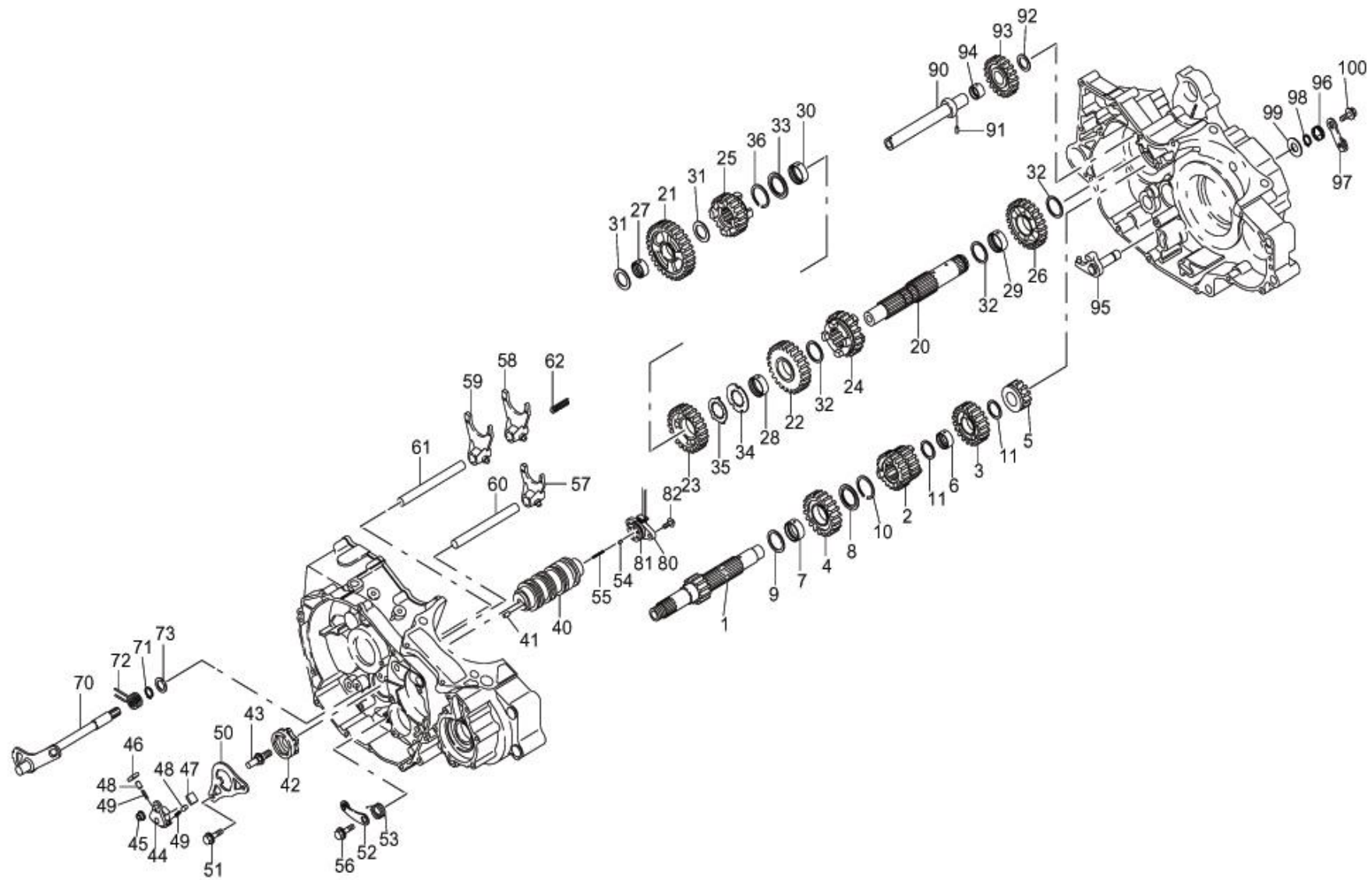

### 13. CLUTCH (No.2)

Item	Part-No.	DL-Part No.	Part Name	Specification	Q'ty of Usage	Note
30	283-86407-03		COLLAR (SPLINE)		1	
31	283-86803-03		WASHER		2	
32	283-87402-03		WASHER		3	
33	283-86701-03		SPLINE WASHER		1	
34	283-86801-03		WASHER		1	
35	283-86702-03		LOCK WASHER		1	
36	283-86901-03		CLIP		1	
*40	283-87602-01		SHIFT DRUM COMPL.	Incl. 41	1	
41	283-87801-03		DOWEL PIN		1	
42	283-87702-03		SHIFT CAM		1	
43	283-8B001-03		SHIFTER PIN		1	
44	283-8B102-03		DRUM SHIFTER		1	
45	283-8B201-03		SHIFTER COLLAR		1	
46	283-8B301-03		RATCHET PAWL A		1	
47	283-8B401-03		RATCHET PAWL B		1	
48	283-8B501-03		PAWL PLUNGER		2	
49	283-8B601-03		SPRING (PLUNGER)		2	
50	283-8B701-03		GUIDE PLATE		1	
51	011-00604-70		FLANGE BOLT	M6×20mm	2	
52	283-8C301-01		STOPPER ARM COMPL.		1	
53	283-88005-13	A110046-00	SPRING (STOPPER)		1	
54	283-88101-03		POINT (NEUTRAL)		1	
55	283-88201-03		SPRING (POINT)		1	

# 13. CLUTCH (No.2)

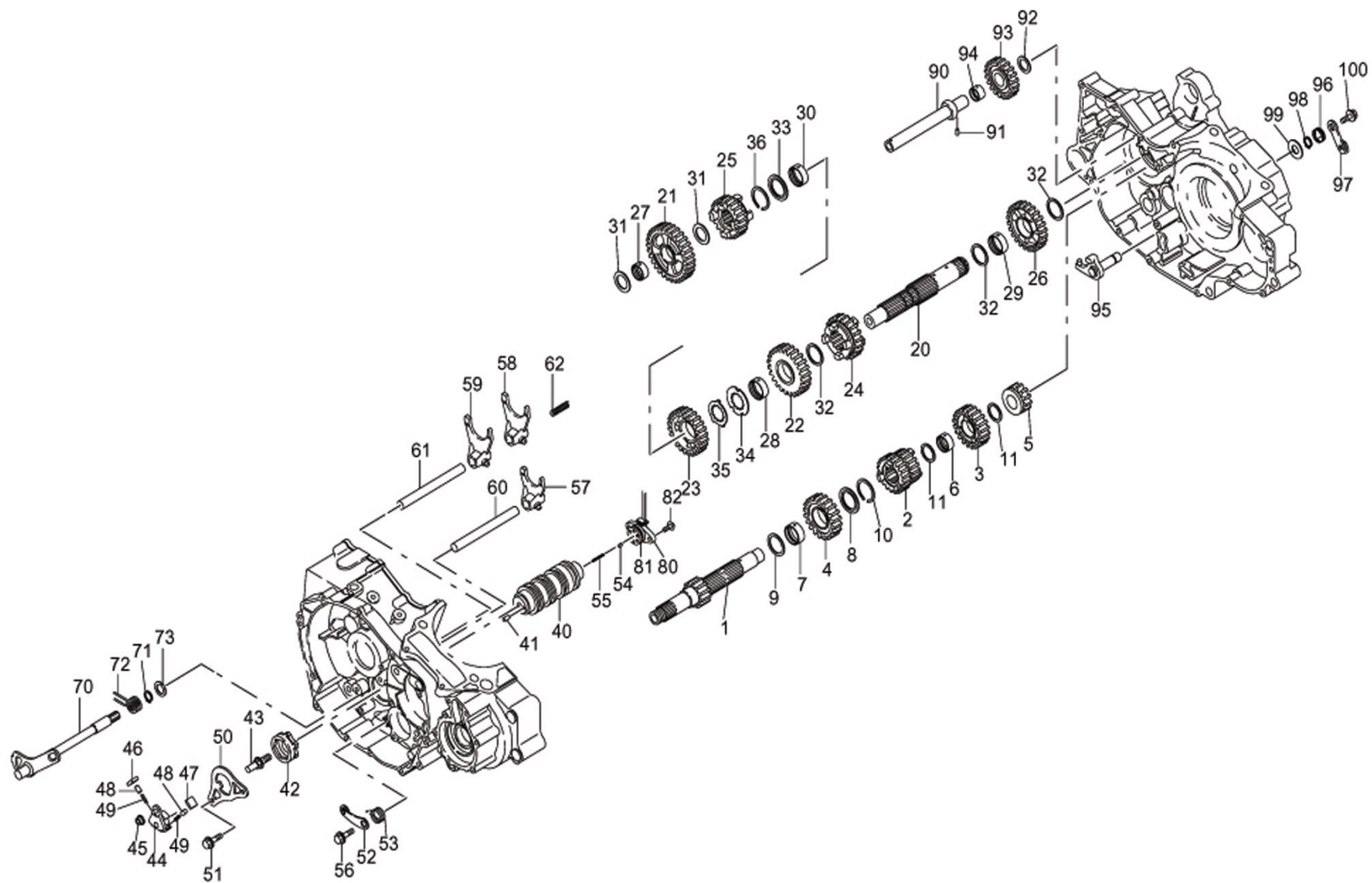

### 13. CLUTCH (No.2)

Item	Part-No.	DL-Part No.	Part Name	Specification	Q'ty of Usage	Note
56	283-89906-03		BOLT (STOPPER)		1	
57	283-88410-03		SHIFT FORK (MAIN)		1	
58	283-88411-03		SHIFT FORK (LEFT)		1	
59	283-88412-03		SHIFT FORK (RIGHT)		1	
60	283-88505-03		FORK SHAFT		1	
61	283-88506-03		FORK SHAFT		1	
62	283-88601-03		SPRING (FORKSHAFT)		1	
70	283-8C002-01		SHIFT SHAFT COMPL.	Incl. 71,72	1	
71	283-86902-03		SNAP RING		1	
72	283-8C201-03	A110050-00	RETURN SPRING		1	
73	283-86807-03		WASHER		1	
*80	283-89304-00		SWITCH (POSITION) ASSY.	Incl. 81	1	
81	024-02100-10		"O" RING		1	
82	013-10500-30		SCREW AND WASHER ASSY.	M5×20mm	2	
*90	283-8A001-01		REVERSE SHAFT COMPL.	Incl. 91~94	1	
91	283-87801-03		DOWEL PIN		1	
92	283-86805-03		WASHER		1	
93	283-8A101-03		REVERSE IDELE GEAR		1	
94	283-86408-03		COLLAR		1	
95	283-8A201-01		REVERSE ARM COMPL.		1	
96	283-8A401-03		REVERSE ARM SPRING		1	
97	283-8A301-03		REVERSE ARM LEVER		1	
98	003-15120-00		SNAP RING		1	
99	283-86806-03		WASHER		1	
100	011-00604-40		FLANGE BOLT	M6×12mm	1	

# 14. COVER(CHAIN)

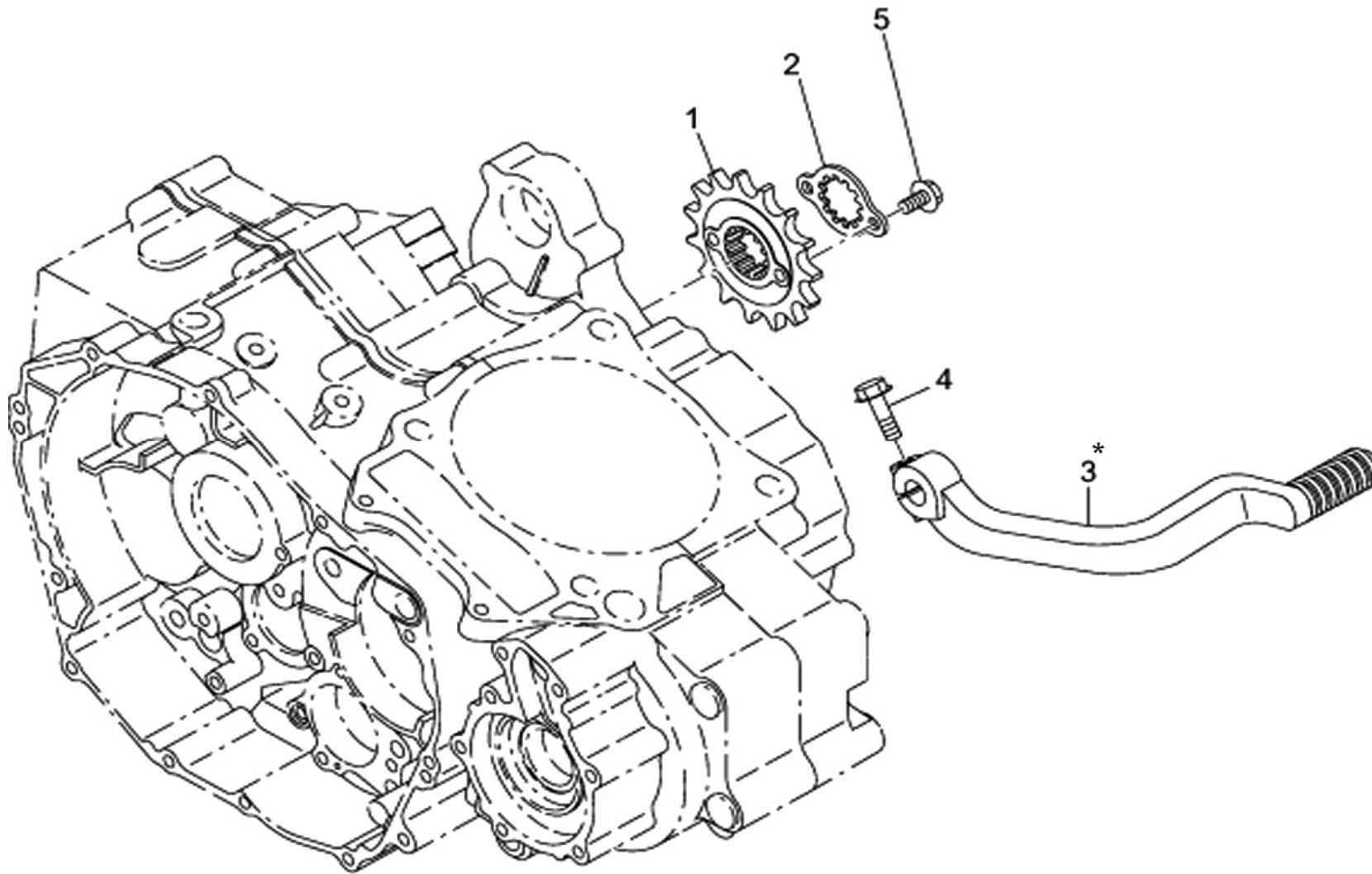

## 14. COVER(CHAIN)

Item	Part-No.	DL-Part No.	Part Name	Specification	Q'ty of Usage	Note
1	283-89603-03		SPROCKET 14T		1	
2	283-89702-03		FIXING PLATE		1	
3	283-89802-01		SHIFT PEDAL COMPL.		1	901
*		F170068-00	SHIFT PEDAL COMPL.		1	902
*		F190069-00	SHIFT PEDAL COMPL.		1	903
4	011-00602-40		FLANGE BOLT	M6×25mm	1	
5	011-00604-40		FLANGE BOLT	M6×12mm	2	